

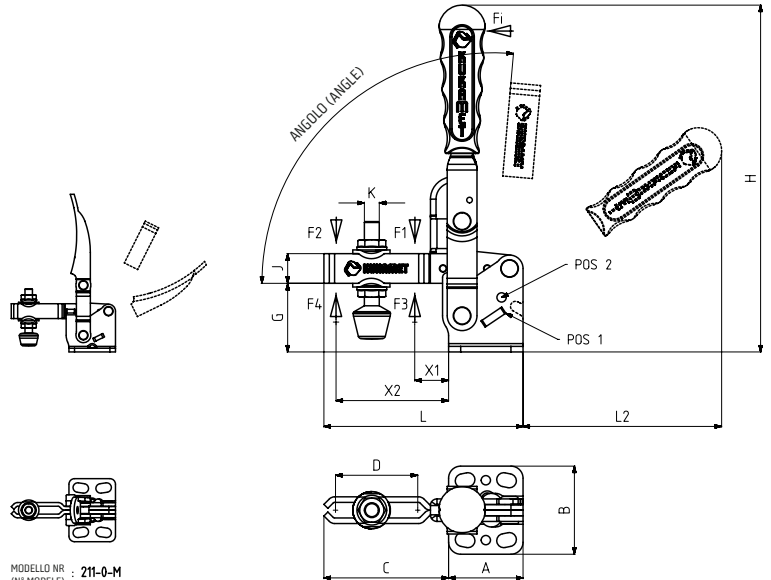

MODELLO NR	INOX	NERO (NOIR)	F1 (N)	F2 (N)	F3 (N)	F4 (N)	Fi		FILETTO PUNTALE (FILETAGE PRESSEUR)	ANGOLO (ANGLE) (± 5 °)		PESO (POIDS) (gr ±2%)
							(X1 CARICO (CHARGE) (F1.Fi))	(X2 CARICO (CHARGE) (F2.Fi))		Angolo di inclinazione del braccio Angle d'inclinaison du bras		
										POS1	POS2	
211-0-M	S 211 -	B 211 -	550	350	700	455	10:1	5:1	M4X25	115°	-	80
211-0	S 211 -	B 211 -	550	350	700	455	10:1	5:1	M4X25	115°	-	72
211-1	S 211 -	B 211 -	750	500	1000	680	12:1	8:1	M5X35	105°	-	155
211-2	S 211 -	B 211 -	1200	700	1400	925	12:1	7,5:1	M6X40	105°	-	230
211-3	S 211 -	B 211 -	2000	1400	2500	1560	11:1	8:1	M8X50	105°	-	415
211-4	-	B 211 -	3000	2000	3300	2200	11,5:1	8:1	M10X70	135°	105°	900
211-5	-	B 211 -	4500	2500	5000	3000	12:1	7:1	M12X80	135°	105°	1540

F1 - F2 : FORZA DI ESERCIZIO (FORCE EXERCÉE), F3 - F4 : CAPACITA' DI TENUTA (CAPACITE DE MAINTIEN), Fi : FORZA APPLICATA (FORCE APPLIQUEE)



MODELLO NR. : 211-0-M
(N° MODELE) :
(MANOPOLA NON RIVESTITA)
(MANCHE METAL)

Base Orizzontale
Base de Montage Horizontale

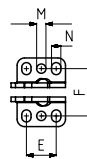

MODELLO NR
(N° MODELE) : 211-1

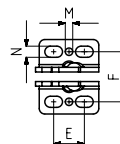

MODELLO NR
(N° MODELE) : 211-2

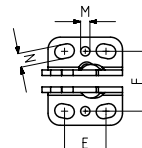

MODELLO NR
(N° MODELE) : 211-3

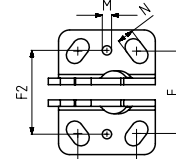

MODELLO NR
(N° MODELE) : 211-4

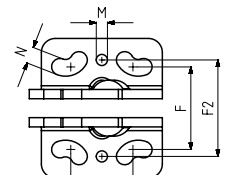

MODELLO NR
(N° MODELE) : 211-5