

MODELLO NR	NERO (NOIR)	F1 (N)	F2 (N)	F3 (N)	F4 (N)	Fi		FILETTO PUNTALE (FILETAGE PRESSEUR)	ANGOLO (ANGLE) (± 5 °)		PESO (POIDS) (gr ±%2)
						(X1) CARICO (CHARGE) (F1:Fi)	(X2) CARICO (CHARGE) (F2:Fi)		Angolo di inclinazione del braccio (Angle d'inclinaison du bras)		
									POS 1	POS 2	
213 - 1	B 213 - ....	750	500	1000	680	12:1	8:1	M5X35	135°	105°	170
213 - 2	B 213 - ....	1200	700	1400	925	12:1	7,5:1	M6X40	135°	105°	265
213 - 3	B 213 - ....	2000	1400	2500	1560	11:1	8:1	M8X50	105°	-	470
213 - 4	B 213 - ....	3000	2000	3300	2200	11,5:1	8:1	M10X70	135°	105°	1050
213 - 5	B 213 - ....	4500	2500	5000	3000	12:1	7:1	M12X80	135°	105°	1760

F1 - F2 : FORZA DI ESERCIZIO ( FORCE EXERCICE ), F3 - F4 : CAPACITA' DI TENUTA ( CAPACITE DE MAINTIEN ), Fi : FORZA APPLICATA ( FORCE APPLIQUEE )

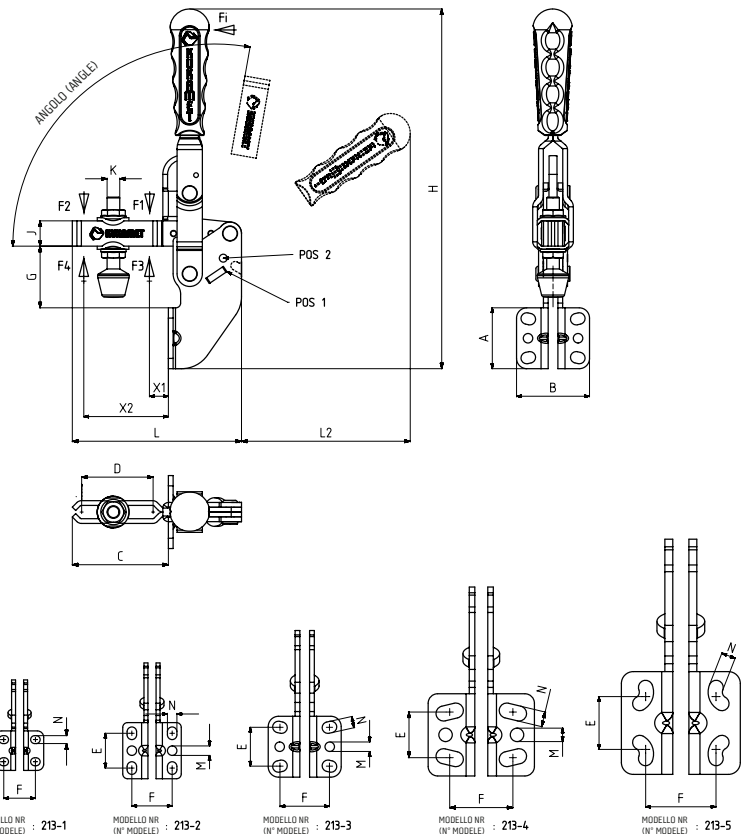

**Base Frontale**  
Base de Montage Frontale

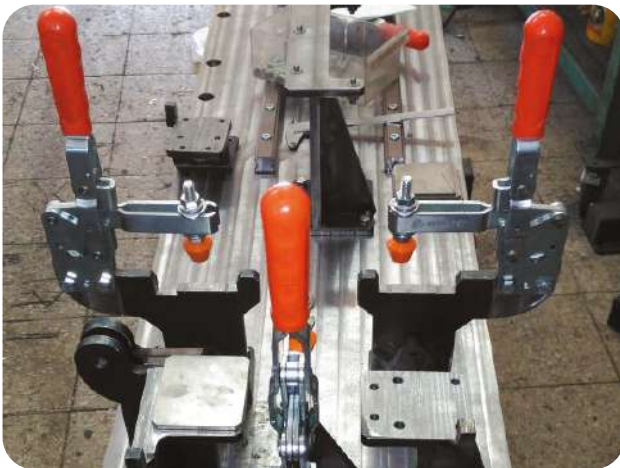

MODELLO NR	A	B	C	D	E	F	G	H	J	K	L	L2	M	N	X1	X2
213 - 1	25	30,5	38	26	14	20	22,5	150	10	M5	70	75	-	5 x 6	12	28
213 - 2	35,5	37	58	42	22	25,5	25,5	175	13	M6	94	85	Ø 6	6 x 8	15	45
213 - 3	38,5	46	61	42	24,5	31,5	39	228	16	M 8	107	110	Ø 6	7 x 9	19	46
213 - 4	52	67	91	67	29	40	48	292	20	M10	152	160	Ø 8,5	9,5 x 17,5	24	72
213 - 5	65	75,5	118,5	88	33,5	44,5	59	328	25	M12	195	165	-	9 x 19,5	30	95