



Nuovo

MODELLO NR	F1 (N)	F3 (N)	Fi	ANGOLO (ANGLE) (± 5°)	PESO (POIDS) (gr ±%2)
			CARICO (CHARGE) (F1)		
221-4-C-L	1500	5000	5:1	100°	1310
221-6-C-L	2000	6000	5:1	100°	2340

F1: FORZA DI ESERCIZIO (FORCE EXERCÉE), F3: CAPACITÀ DI TENUTA (CAPACITÉ DE MAINTIEN), Fi: FORZA APPLICATA (FORCE APPLIQUÉE)

Base Orizzontale (Con Arresto Quando Aperta)
 Corps Avec Base de Montage Horizontale (Verouillée Ouverte)

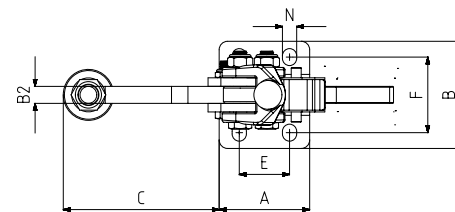
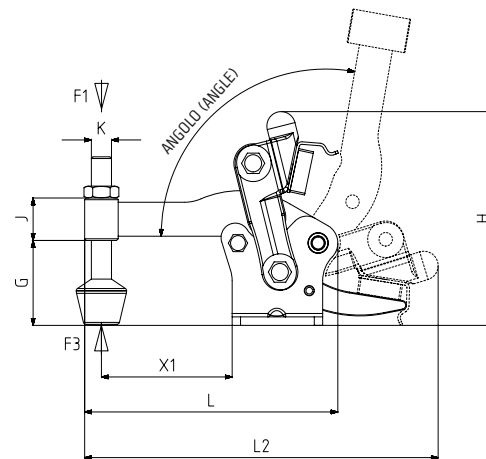

221-L

Pagina/Page: 25



241-L

Pagina/Page: 33



914

Pagina/Page: 121

MODELLO NR	A	B	B2	C	D	E	F	G	H	J	K	L	L2	M	N	X1
221-4-C-L	54	63	10	88	-	30	44,5	49	126	27	M12	151	210	-	8,5 x 10	78
221-6-C-L	70	74	12	111	-	45	52	68	159	32	M12	191	267,5	-	10,5 x 11,5	98,5